

MOBILE DIESEL GENERATOR SET
FUEL: DIESEL
ENGINE: HYUNDAI
SPECIFICATION SHEET

Power Ratings		kW	kVA
Power	Standby	40.0	50.0
	Prime	36.0	45.0
Ampage 0.8 PF	240V	120	
12-wire voltages: 1P = 120/240; 3P = 120/208, 120/240, 480/277			

Rating Definitions: Rated for 1800 rpm.

Standby ratings is applicable for supplying emergency power for the duration of the utility power outage. No overload capability is available for this rating. A standby rated engine should be sized for a maximum of an 80% average load factor and 200 hours of operation per year. This includes less than 25 hours per year at the Standby Power rating. Ratings are established based on 85°F (29°C) and an elevation of 1,000 feet (305 meters).

STANDARD FEATURES:

Tradewinds Power Corp (TPC) Diesel Hyundai powered mobile configured generator sets are self contained standby generator packages complete with mounted auto control panel, air cleaners, exhaust silencers, and other accessories mounted on a steel frame, with vertical radiator and exhaust discharge and oil & coolant drain Lines. All TPC systems and components are prototyped, assembled and tested within a purpose built packaging, manufacturing, and test facility.

Engine:

- Hyundai model D24 diesel engine
- EPA Tier 4 - Final & Stage IIIB
- Direct injection high pressure common rail @ 1800 bar
- Heavy duty rated for standby and continuous prime power operation
- Cooling system capable of operation at 120°F ambient
- The Hyundai 146 CID diesel is best in class for meeting the latest emission regulations. Exhaust after-treatment includes Diesel Oxidation Catalyst (DOC)
- Turbo-Intercooler for maximum efficiency and compact power
- Low noise and vibration due to better combustion and engine balance
- Cleaner burn means no DPF and lower maintenance costs

Alternator:

- Stamford 4-pole, 12-wire brushless generator, single bearing
- Class H insulation system utilizes an unsaturated polyester varnish for optimal insulation life and superior moisture protection. A tropical insulation is added for increased environmental protection
- Optimized electrical design with four-pole, brushless features, utilizes a 2/3 pitch winding to minimize harmonic distortion
- Vacuum-impregnated windings with fungus-resistant epoxy for dependability and long-life
- AS480 AVR fitted as standard, with this self-excited system the main stator provides power via the AVR to the exciter stator. The high efficiency semi-conductors of the AVR ensure positive build-up from initial low levels of residual voltage.

Starting System:

- 12-VDC Starter
- Engine mounted Battery Charging Alternator
- Battery Cables and Rack along with Grounding Strap

Factory Fitted Options:

- Weather Protective Enclosure constructed of Marine Grade Aluminum 0.125 thickness, SS Hardware, white powder coat paint finish on both sides, sound Insulation resistant to high temperatures, fuel and oil, hinged / removable / keyed alike doors, and 175mph wind load rating
- Double walled UL142 base mounted daily service fuel tank
- DOT road towing trailer

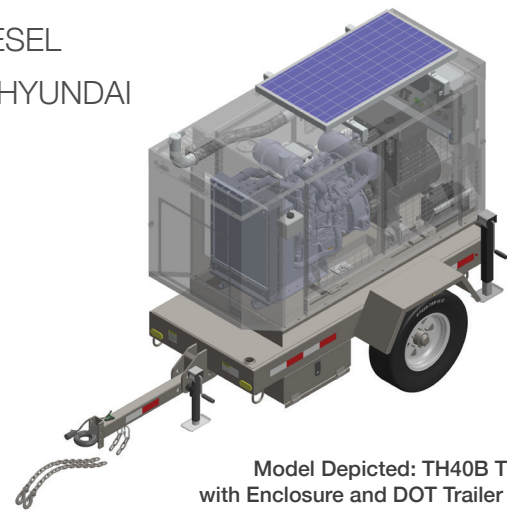

Model Depicted: TH40B T4F
with Enclosure and DOT Trailer Options

CONNECTION PANEL & CONTROLS:

1. 2 x (2 x Receptacle 120V-20A GFCI)
2. 1 x 240V 50A Twist Lock
3. 5 x Compression connector lugs
4. 120V AC 1ph, 60hz input power for battery charger and water heater if required
5. Rear 400A 3Ph Camlock

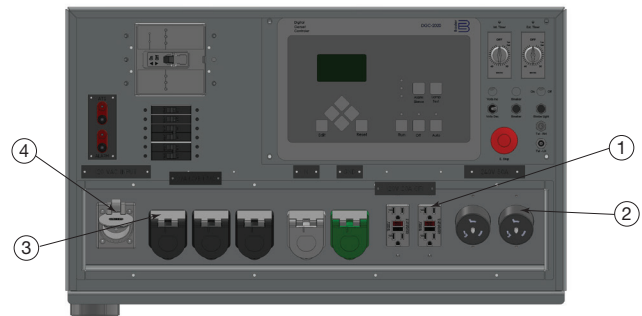
AUTOMATIC GENERATOR CONTROLLER DGC2020:

- Automatic generator controller with analog display of all functions
- Microprocessor Based, Navigation key with large LCD display
- SAE J1939 CANBUS Communication
- Event Recording
- Transfer Switch Control (main failures)
- Alternator Protection: under/over voltage, under/over frequency
- Engine Protection: Low oil pressure, High coolant temperature, Over speed & over crank, Sender Unit failure, Fuel Failure sensor, Battery Charger Failure
- All protections are programmable as Alarms or Pre-alarms
- Metering (ample range): Volts, Current, Hz, Watts, VA, Pf, Oil Pressure, Coolant Temperature, RPM, DC Volts, Fuel Level, Engine running time
- Engine Control with Timers
- External remote start input (on or off load)
- 6 programmable contact inputs - 4 contact outputs

SCADA interface points:

- No fuel, Low fuel
- Low battery charging voltage
- Engine running
- Common engine alarm
- Switch in Emergency Position

Optional Equipment:

- Low coolant level switch
- 17-light remote annunciator panel
- Low coolant level switch

WARRANTY:

- Engine covered under the original equipment manufacturer's warranty - consult Tradewinds Power Corp for details
- Complete package supplied with 2-year limited warranty

The manufacture reserves the right to change the design or specifications without notice and without any obligation or liability whatsoever.

ENGINE SPECIFICATION:	
Manufacturer	Hyundai
Model	Hyundai D24
Emissions	EPA Tier 4 - Final & Stage IIIB
Engine speed (rpm)	1800
Max. (Cont.) HP Power 1800 rpm	68
Cylinder arrangement	In-line 4
Engine combustion system	Diesel Direct Injection
Aspiration	Turbo-intercooler
Fuel direct injection system (Diesel)	High Press. Com. Rail 1800 bar
Number of Cylinders	4
Displacement in ³ (liters)	145.97 (2.392)
Bore and Stroke inches (mm)	3.55 X 3.70 (90 x 94)
Cooling	Water-cooled
Governor	Electronic
Starting aids	Glow Plugs
Compression ratio	17.0:1
Air cleaner type	Medium duty dry type
Sound at 1m from engine block dBA	TBA
Max. Exh. Temp at full load degrees °F (°C)	787 (437)
Exhaust aftertreatment	Diesel Oxidation Catalyst (DOC)
COOLING SYSTEM FOR OPERATING AT 120°F AMBIENT:	
Cooling System	Water-cooled
Engine Coolant Capacity quarts (Liters)	4.23 (4.0)
Fan	Belt driven pusher fan
Radiator	Engine mounted
Eng. Cooling air flow - ft ³ /min (m ³ /min)	TBA
LUBRICATING SYSTEM:	
Total lubricating capacity quarts (Liter)	9.09 (8.6)
Recommended lubricating oil grade	SAE 10W-30
Oil Pressure – psi (kPa)	43.5 (300)
Oil Filter	Full flow spin on, cartridge type

ENGINE ELECTRICAL SYSTEM:	
Starting motor voltage	12 volt
Charger	90 A Alternator with DC output
Wet Cell Battery	Lead Acid
ALTERNATOR:	
Configuration	Brushless, 3-Phase, 12-wire, 4-pole
Frequency	60 Hz
Voltage regulation	AS480 AVR
No load to full load voltage regulation	+/- 1%.
Coupling	SAE Adapter, Flexible Disc, Direct
Bearing	Single
Manufacturer	Stamford
Model	PI144K
Load acceptance	One Step, 100% per NFPA 110
Compliance	NEMA, IEEE & ANSI for temp. rise
Construction	Self ventilated drip-proof
FUEL CONSUMPTION: PER HOUR GALS (LITERS)	
100%	3.41 (12.9)
75%	2.56 (9.7)
50%	1.77 (6.7)
25%	1.00 (3.8)
CONTROL PANEL SPECIFICATIONS:	
Manufacturer (Model)	Basler (DGC-2020ES)
Operating power/consumption	6-32 VDC; Average load 14.2W
Communications	UL 508 R & CSA C22.2 #14
ENCLOSURE AND ARRANGEMENT OF COMPLETE ASSEMBLY:	
Coupling	Close coupled to flywheel flange
Enclosure (Option)	Aluminum for weather protection
Base arrangement	Rigid steel base frame with AVMs
Spill containment (Option)	UL double wall base mounted

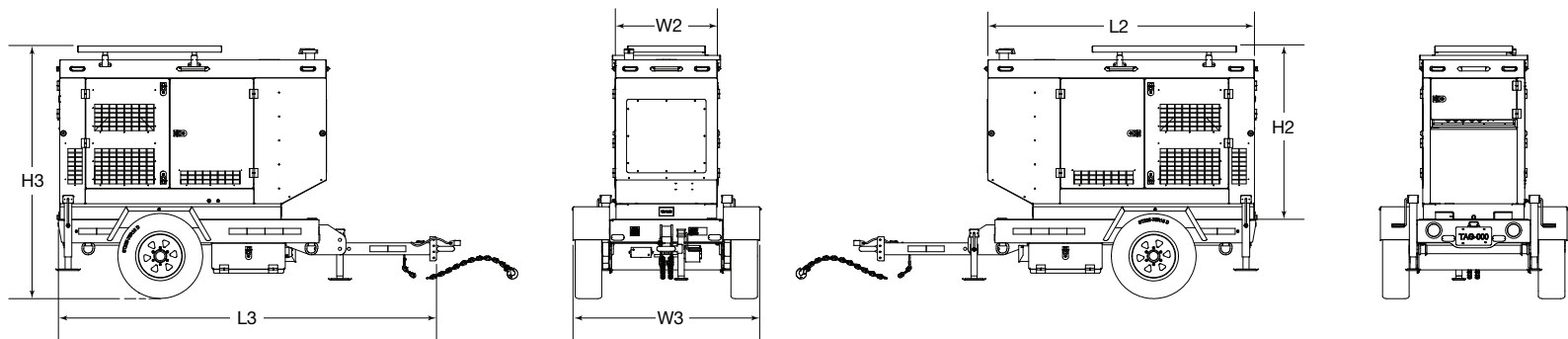
DIMENSIONS & ARRANGEMENT DRAWING MOBILE MODEL (WITH DOT TRAILER & ENCLOSURE OPTION): TH40B T4F

KEY DIMENSIONS AND WEIGHT BASIC OPEN SET, SOUND ENCLOSURE AND MOUNTED ON DOT TRAILER (* = Option Equipment)										
Description (inches)	Height	Width	Length	Dry weight lbs	Wet Weight lbs	Sound dBA	Fuel Tank Gals *			
Open Set	H1	44.00	W1	36.00	L1	74.00	1497	1578	82	80
Enclosed Set *	H2	46.38	W2	34.00	L2	89.00	1780	1826	68	
Trailer mounted *	H3	73.35	W3	62.27	L3	131.47	3158	3309		